

Panel Mount Tachometer Model DT-5TG (VDC)

Instruction Manual



Features

One of the most advanced on the market today, this microprocessor-based panel tachometer not only measures rotational, linear and flow rate speeds, but can also function as an elapsed time counter and ratio meter. By choosing the desired input/output module(s), you can design virtually any system imaginable.

- Mounts easily — no brackets or screws or any other hardware needed.
- Tolerates a wide variation of voltages.
- Immune to electrically noisy environments.
- Programmable parameters and functions via front panel membrane push-button switches.
- Accepts a variety of input and output modules
- No need to remember mathematical formulas.
- Highly accurate.
- Self-testing.

Dimensions (mm)

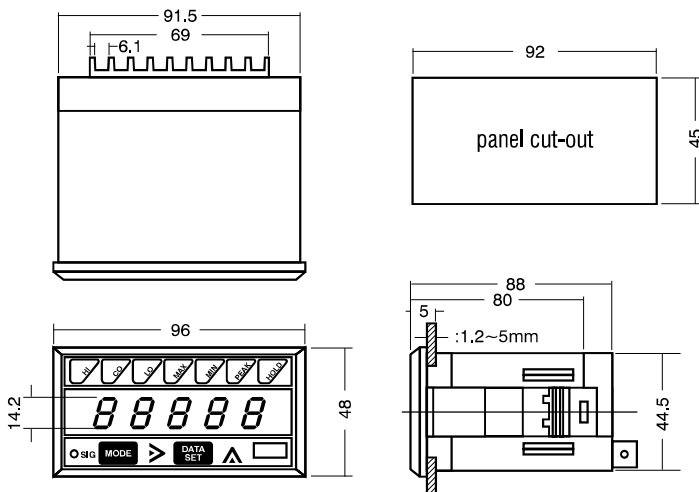

Operational Precautions

- If the unit is used in a caustic environment, we suggest you use a NEMA 4X enclosure.
- Keep unit free of vibration and shock.
- When installing unit, keep power and sensor wires separate. Tie cable shield to terminal E (earth ground).
- After inserting wires, tighten terminal screws securely.

Specifications

Function	Rate Measurement	Elapsed Time Counter
Display Range	0.0000–9.9999 0.000–99.999 0.00–999.99 0.0–9999.9 0–99999	99.99 sec. 99 min. 59 sec. 99 hours 59 min.
Measuring range	10–99999 rpm (at 1p/r), 0.2–30000 rpm (at 60p/r)	
Update Time	0.25, 0.5, 1, 2, 4, 8, 16 sec., selectable	
Display	5-digit LED (0.56" or 14.2 mm high)	
Time base	Controlled by a 4.194304 MHz crystal	
Accuracy	±0.008% ± 1 digit	
Measuring system	CPU controlled	
Input no. of p/r	1–9999 (programmable)	
Input signal characteristics	Sine wave–max frequency 10 kHz Square wave–max frequency 30 kHz open collector Contact closure–max frequency 20 Hz	
Input signal amplitude	Sine wave (0.3–30 VP–P) Square wave LO: 0–1.5 V, HI 4–30 V	
Input impedance	10 k ohms for magnetic pickup, rotary pulse generator and proximity switch only	
Voltage output	12 VDC ± 5% (50 mA max) to power sensors	
Applicable Sensors	rotary pulse generator, magnetic pickup, proximity switch, retro-reflective	
Ambient temperature	32°–113° F (0°–45° C)	
Power consumption	1W (5W when using optional modules)	
Voltage requirements	9–35 VDC	
Dimensions	3.46"L x 1.88"H x 3.78"W (88L x 48H x 96W mm), includes bezel, fits 1/8 DIN cutout	
Weight	0.55 lbs (250g)	

Installation

Mounting Unit

Our 1/8 DIN case design eliminates the need for brackets and screws for installation. With the tachometer in a level position, insert it into the panel cutout. Gently push the face of the unit until the front bezel locks into place. If the tachometer case is loose, adjust the integral bracket with the enclosed tool.

Removing unit

From the rear of the tachometer, alternately push the unit from the left and right. This will free it for easy removal.

Mounting Bracket Adjustment

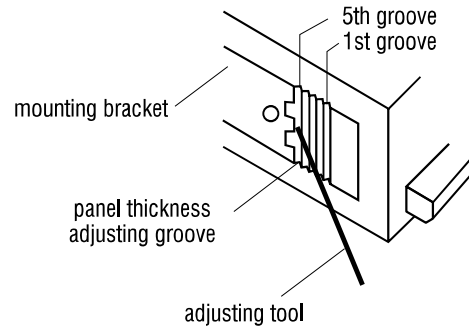

Thickness of Panel

1.2 – 1.6 mm
1.8 – 2.5 mm
2.8 – 3.6 mm
4.0 – 4.5 mm
5.0 mm

Panel Thickness Adjusting Groove

5th groove (factory setting)
4th groove
3rd groove
2nd groove
1st groove

Connections

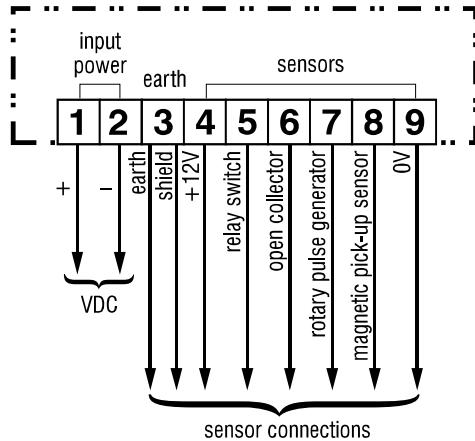

- 1&2 DC input terminals.
- 3 Earth ground. Connect all cable shielding to this terminal.
- 4 12 VDC 50mA max. This sensor power supply is for any sensor that requires external power
- 5 Switch closure input. To be used with a relay or solenoid. The input frequency must be less than 20Hz.
- 6 For use with open collector sensors. Connect the sensor's signal output wire. No need for an external pull-up resistor.
- 7 Terminal to accept signals from rotary encoders or pulse generators.
- 8 Standard input terminal for magnetic pick-ups and proximity switches.
- 9 Signal ground or common.

Mode Selections

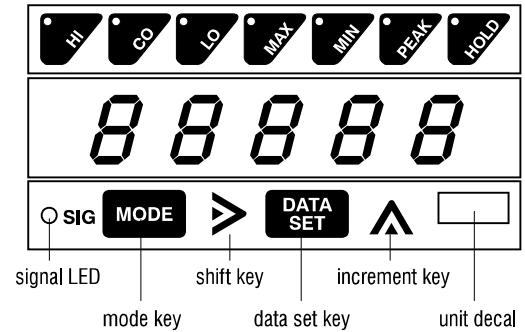

The DT-5TG has five modes of operation. Each mode uses separate parameters for you to program:

<u>Mode</u>	<u>Function</u>	<u>Application</u>
1	Rate measurement (frequency input)	Measures rotational linear or flow rate speeds. Factory set.
2	Elapsed time counter	Times variable processes.
3	Rate measurement	For tachogenerator or voltmeter. Requires input module DOP-VF.
4	Ratio meter	Compares two signals in either absolute or percent ratio. Requires input module DOP-RM.
5	Self test	Diagnostically tests LED display, panel switches and input circuitry.

Sensors

Shimpo offers a large selection of sensors to meet you application needs. The chart below shows the optimum sensor to use when designing your system. Please call us for more information.

SENSOR	FREQUENCY TYPE	TERMINAL NUMBERS	FREQUENCY OR RPM RANGE	OPERATION TEMPERATURE
RE1B-60C RE1B-600C RE1B-1000C	Rotary Pulse Generator	4, 7, 9, 4, 7, 9, 4, 7, 9,	0-5000 rpm 0-3000 rpm 0-1800 rpm	+14° F to +122° F +14° F to +122° F +14° F to +122° F
BI2-S12 DJ2-G SE-G	Proximity Switch Proximity Switch Proximity Gear Sensor	4, 6, 9, 4, 8, 4, 7, 9,	0-2 KHz 0-1 KHZ 0-8KHz	-13° F to +158° F -68° F to +140° F -4° F to +158° F
RS220H MCS-625	Retro Reflective Sensor	4, 7, 9, 4, 6, 9,	0-500 Hz 0-250 Hz	+14° F to +140° F -22° F to +120° F
3030AN MP-10 3070A*	Magnetic Pick-up	8, 9, 3, 8, 9, 3, 3, 8, 9,		-100° F to +225° F -40° F to +221° F -100° F to +200° F
Switch Closure	Relay or Solenoid	5, 9,	<20 Hz	

* explosion proof

Setting Modes

1. Apply any voltage between 9–35 VDC to terminals 1 and 2. When power is applied, the display will show all zeroes. After half a second, the display will change to **0**.
2. Press **mode** and **data set** keys for at least 5 seconds. A zero will flash until **1** appears on the display.
3. Press the **increment** key to select the mode you want. Mode sequence will depend on input module
4. Press **mode** key. You're now ready to program the parameters for the mode you have selected.

Mode 1: Rate Measurement

The DT-5TG can easily measure any rotational, linear or flow rate speed. Each parameter function dictates the necessary steps when preparing a system application. Parameters 2 and 3 can be measured with a hand-held digital tachometer (no need for arithmetic calculations).

Parameter	Function Setting	Factory	Range
1	Pulses per revolution	1p/r	1 – 9999
2	Sensing rpm	50,000 rpm	
3	Display units	50,000 rpm (rpm, fpm, ips)	
4	Decimal point	none	0 – 4th place
5	Minimum rpm (sensor)	10 rpm	
6	Update time	1	.25, .5, 1, 2, 4, 8, 16
7	Acceleration	0	0, 1, 2

Setting Parameters

Parameter 1:

Pulses Per Revolution from Sensor

Here's how to change the parameter from 1 to 60 pulses per revolution ("p/r"):

1. Set unit to **mode 1**.
2. Press **mode** key.
3. Press **shift** key to select the desired digit.
4. Press **increment** key 6 times.
5. Press **shift** key.
6. Press **increment** key 9 times.

Parameter 1 is now set for 60 p/r.

Parameter 2: Sensing RPM

To change the parameter from 50,000 to 1,000 rpm.

1. Press **mode** key
2. Press **shift** key
3. Press **increment** key five times.
4. Press **shift** key
5. Press **increment** key.

Setting Parameters (cont'd)

Parameter 3: Display Units

Program this parameter to the desired display value corresponding to the parameter 2 setting. For example, suppose a conveyor is running at 157 fpm and 1,000 rpm sensing speed. This parameter would then be programmed for 157.

3 - - - - 1. Press **mode** key.

50000

➤ **▲** **00157** 2. Press **increment** and **shift** keys to change display.

To get a decimal point, increase the parameter 3 setting by a power of 10, depending on the number of decimal places needed. For one decimal place (in this example), program the display for **01570**. For two places, program **15700**.

Parameter 4: Decimal Point

4 - - - - 1. Press **mode** key (Skip to parameter 5 if you don't want a decimal point).

➤ **00157** 2. Press **shift** key to select position of decimal point.

Parameter 5: Minimum RPM (sensor)

Set this parameter to the highest value possible.

5 - - - - 1. Press **mode** key.

➤ **▲** **00010** 2. Press **shift** and **increment** keys to change display.

Parameter 6: Update Time

6 - - - - 1. Press **mode** key.

➤ **1** 2. Press **shift** key to select update time.

Parameter 7: Acceleration

This parameter is useful when rate speeds accelerate or stop rapidly. If the tachometer senses a large rate change, the update time automatically switches to .25 seconds. When the tachometer senses a constant rate, the update time is determined by parameter 6.

7 - - - - 1. Press **mode** key

➤ **0** 2. Press **shift** key to set parameter:

0 = No function

1 = Rapid stop

2 = Acceleration (input frequency must be ≥ 7 Hz)

Parameter settings are now complete. Press **data set** key to start measuring.

Field Adjustment

In the rate measurement mode, parameter 3 can be adjusted without following the parameter sequence. For example, suppose the initial parameter 2 and 3 settings are 50,000 rpm. But during actual measurements, the display shows 3,800 rpm when the sensing speed is 3,500 rpm. The DT-5TG can be quickly adjusted:

1. Press **mode** and **increment** keys simultaneously for 5 seconds.
2. Press **shift** and **increment** keys to make adjustment.
3. Press **data set** key — you're now ready to measure speed.

If the display shows **EE-OO**, the ratio between parameter 2 and 3 is too large. Press **data set** key and readjust these parameters according to the parameter setting procedure outlined earlier.

Mode 2: Elapsed Time Mode

This mode monitors the time of a continuously variable process. Say, for example, a baker wants to know the amount of time needed to bake cookies. By using a stopwatch, he could measure the amount of time it takes at a known speed of the conveyor. Or, the baker could calculate this time by using the distance formula $d=vt$. By knowing the calculation time (parameter 4) and rpm of the sensing gear (parameter 2), the baker can continuously monitor the time as the process varies.

Parameter	Function Setting	Factory	Range
1	Sensing gear -pulses/ revolution	1	1 - 9999
2	Sensing gear -rpm	200	
3	Time units	(=.)	(-.)=sec/sec (=.)=min/sec or hr/min
4	Calculation time	02=.00	
5	Update time	1	.25, .5, 1, 2, 4, 8, 16

Parameter 1:

Sensing Gear – Pulses per Revolution

This example shows how to change the parameter from 1 to 60 pulses per revolution.

1. Set the unit to **mode 2**.
2. Press **mode** key.
-
-
3. Press **shift** key 4 times.
4. Press **increment** key 6 times.
5. Press **shift** key.
6. Press **increment** key 9 times.

Parameter 2: Sensing Gear — RPM

Here's how to change the parameter from 200 to 100 rpm:

1. Press **mode** key.
-
-
2. Press **shift** key 3 times.
3. Press **increment** key 9 times.

Parameter 3: Time Units

1. Press **mode** key.
2. Press **shift** key to select units.

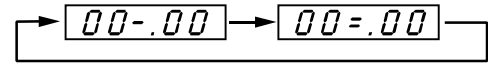

Unit symbols:

- =. hour/minute or minute/second
- . second/second

Parameter 4: Calculation Time

1. Press **mode** key.
-
2. Press **shift** and **increment** keys to program time calculated.

If the display shows **---.E9**, an entry error has been made. Reprogram the unit using the **shift** and **increment** keys.

Parameter 5: Update Time

1. Press **mode** key.
 2. Press **shift** key to select update times.
- DATA SET** The parameter settings are now complete. Press **data set** key to start elapsed time counter.

Mode 5: Self Test

This mode lets you check the LED display and input circuitry.

- 1 -

1. Press **mode** and **data set** keys for five seconds.

▲ - 5 -

2. Press **increment** key and select mode 5.

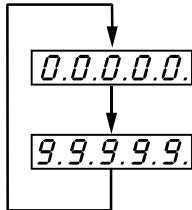

3. Press **mode** key to test display segments and decimal points.

4. Some display functions switches can also be checked. Press these keys to test:

88888

MAX

1.1.1.1.1

MIN

9.9.9.9.9

PEAK

HOLD

5. Press **mode** key. The display will show **1000** and signal **LED** will flash.

6. Press **data set** key. The display will go back to the previous mode of operation.

Display Switches & Functions

The DT-5TG has seven display functions located above the display. All functions have an LED indicator and all but GO have a membrane switch. Here is a brief description of each function:

HI If the display is equal to or greater than the **HI** limit setting, the LED will light and a contact will close.* To program, press **HI** and **mode** keys for one second. Use the **increment** and **shift** keys to set limit.

GO If the display is between the **HI** and **LO** settings, the LED will light and a contact will close.*

LO If the display is equal to or less than the low limit setting, the LED will light and a contact will close.* To program, press **LO** and **mode** keys for one second. Use **increment** and **shift** keys to set limit.

MAX The display will hold the average maximum measurement. To program, press **MAX** and **mode** keys until LED lights.

MIN The display will hold the average minimum measurement. To program, press **MIN** and **mode** keys until LED lights.

PEAK The display will hold the absolute peak measurement. To program, press **mode** and **PEAK** keys until LED lights.

HOLD This function will hold the display indefinitely as long as the unit is powered. To program, press **mode** and **HOLD** keys until LED lights.

*Requires the DOP-CP Triple Relay Output Module.

Note:

- The **HI**, **GO** and **LO** functions are non volatile and may be reset by programming to zero.
- The **MAX**, **MIN**, **PEAK** and **HOLD** functions must be used separately. These functions may be reset by pressing the **data set** key or by interrupting power

Error Codes

<u>Display</u>	<u>Type of Error</u>	<u>What to Do</u>
EE-00	Parameter setting	Press data set key. Enter parameter according to setting range.
EE-01	Hi/Lo setting	Press data set key. Enter the upper and lower limits.
EE-02	Internal setting	Press data set key. Interrupt power at terminals 1 and 2.
EE-03	Memory recall	Press data set key. In sequence, press HI , hold , increment and mode keys.
EE-04	Communication	Check connections with module. Press data set key.
EE-05	error with	
EE-06	module	

Available Modules

Optional modules are available from Shimpo. Choose any of the following modules – no internal hardware modification is required.

Module connectors:

DOP-1A For single module
 DOP-2A For dual module

Modules:

DOP-VF Voltage input
 DOP-RM Ratio input
 DOP-SD RS232C/Mitutoyo output
 DOP-CP Triple relay output
 DOP-BC BCD output
 DOP-FV Voltage/current output
 DOP-PO Parallel output

The DT-5TG is available with one, two, or three module connectors. Each type is indicated by its suffix:

DT-5TG-0 No connector
 DT-5TG-1 1 connector
 DT-5TG-2 2 connectors

Multiple Modules:

In most applications, two modules may be interfaced with the DT-5TG-2. Below are the specific combinations:

	CP	SD	PO	BC	FV	VF	RM
CP	■	■	■	■	■	■	■
SD	■	■	■	■	■	■	■
PO	■	■	■	■	■	■	■
BC	■	■	■	■	■	■	■
FV	■	■	■	■	□	□	□
VF	■	■	■	■	□	□	□
RM	■	■	■	■	□	□	□

■ available

□ can't be combined